

KOBELCO

SK350D_{LC}

SK400D_{LC}

High Reach Demolition Excavator



We Save You Fuel
Achieving a Low-Carbon Society

SK350D_{LC}
SK350DLC-10

SK400D_{LC}
SK400DLC-10



JAPANESE QUALITY

Designed and built for fast setup and maximum productivity.

KOBELCO SK350DLC and SK400DLC high reach demolition excavators utilise a common base boom and exclusive NEXT attachment joint for the ultra-high reach front, insert boom and separate boom.

KOBELCO's demolition excavators with exclusive NEXT joint systems are designed and built to allow quick and easy setup, enabling fast boom assembly and disassembly, for maximum flexibility and productivity on the worksite. The ability to quickly and easily change booms allows you to adapt the machine to the needs of the job, enabling the operator to work at multiple heights throughout the demolition process, with a single machine. This unique and innovative design improves demolition productivity and machine utilisation.

The NEXT joint system has also been designed for ease of transportation, allowing simple assembly and disassembly, and compact transport dimensions. Combined with KOBELCO's excellent fuel efficiency and legendary machine durability, KOBELCO demolition excavators deliver reduced operational costs, less downtime and greater return on investment.

KOBELCO SK350DLC and SK400DLC high reach demolition excavators are built with cutting-edge technology, providing high performance and reliability—to take demolition efficiency to a new level.

KOBELCO improves machine flexibility and utilisation with a common base boom.

Previously, high reach demolition excavators didn't provide the ability to switch from one boom size to another, requiring multiple machines on the jobsite to accommodate different working heights for different stages of the demolition. KOBELCO's solution was to develop a machine structure that enabled one machine to be adapted to multiple front specifications, allowing a single machine to work at multiple heights with different crusher sizes, giving the operator the ability to adapt the machine to the job at hand.

The NEXT system allows fast and efficient boom assembly.



KOBELCO researched in detail how the front boom attachment design could be improved to reduce setup time safely, which resulted in the NEXT attachment system. With a common base boom, simple attachment mechanism and fast hydraulic coupling design, the NEXT system allows the machine and boom segments to be transported separately, then quickly and efficiently assembled on the jobsite.



Two models, multiple reach configurations.

SK350D_{LC}

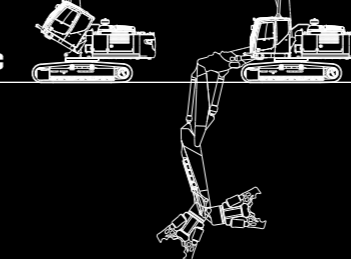

SK400D_{LC}

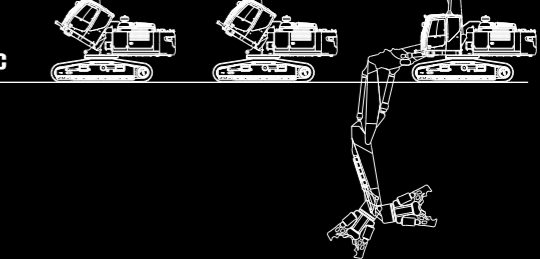

Safe and efficient boom connection. Introducing the NEXT demolition system.



NEXT attachment

The NEXT demolition attachment system with common base boom design has been engineered by KOBELCO to improve worksite efficiency, allowing booms to be assembled quickly and safely. Each boom segment utilizes a common NEXT system connection joint, simplifying assembly/disassembly and transport. Hydraulic piping connections are also simplified, and all assembly/disassembly steps—from pressure release, to joint connection, to fixing of pins—can be completed quickly and safely.

■ NEXT joint system

KOBELCO's original joint system was developed by testing the assembly/disassembly process extensively. The boom attachment can be connected by simply hooking the upper (backside) pin and fixing with the separate opposing pins on the lower side (bottom side).

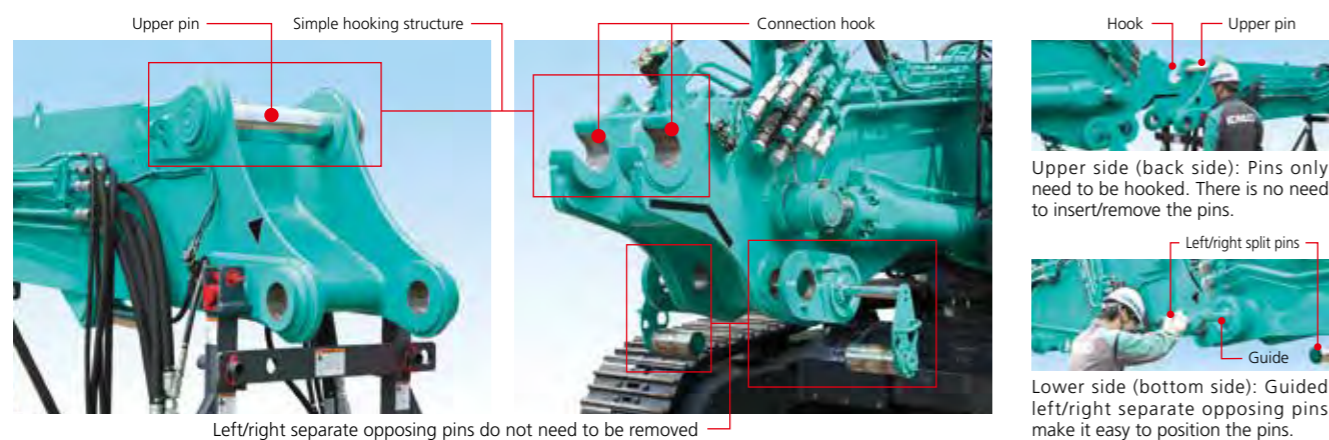

■ Main front boom [NEXT separate boom specification]

Assembly of the separate boom simply means connecting the main front boom with which the jib cylinder foot section is integrated, to the all-purpose base boom using the NEXT joint system. This saves on the work otherwise required to connect the jib cylinder.

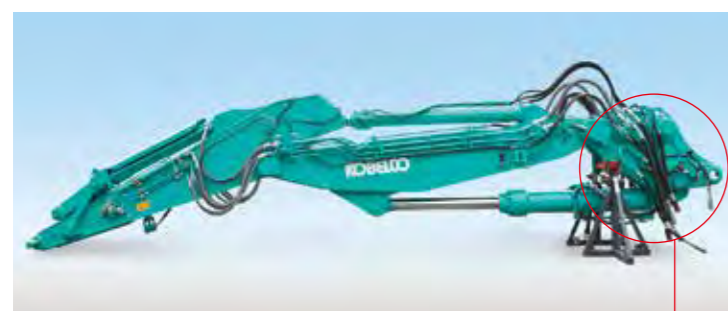

Main front boom

■ Side-mounted hydraulic piping

All attachment joints have the hydraulic piping mounted on the side, adopting a hydraulic multi-coupler system for connecting sections.



Piping connection: Hydraulic multi-coupler system on the side of the boom.



SK350DLC
Separate boom specification

Attachments and base machine designed for easy truck transport.

Attachment height during transport

[NEXT ultra long attachment specification]

The 3-piece NEXT ultra long attachment is designed with the jib cylinder and arm cylinder crossed over the short inter arm, and the back of the arm is flat. The height while in the stored state has been reduced to approx. 2m, to lower the entire height during transport.

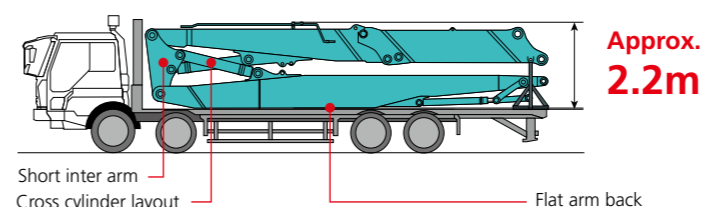

Quick hitch piping

A hydraulic circuit for the quick-hitch arm that allows quick and easy fitting of the front attachment is supplied as standard.



Hydraulic crawler extension / retraction mechanism [SK400DLC]

Crawlers can be retracted to reduce crawler machine width to below 3m for ease of transport. The hydraulic system makes light work of extending or retracting with crawler shoes remaining on ground.

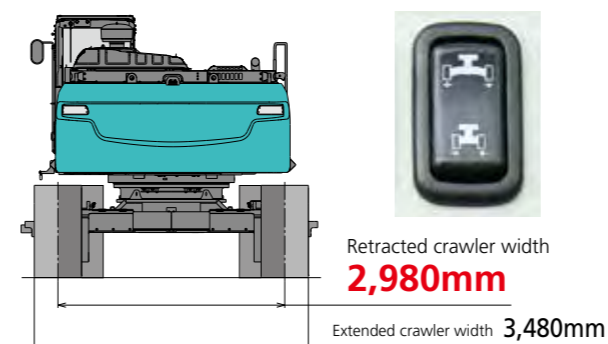

Two-part counterweight [SK400DLC]

The counterweight can be split in two, for ease of transport. One part forms a case into which the other part is housed. It looks neat and uncluttered, and assembly/disassembly is faster than with an integrated counterweight.

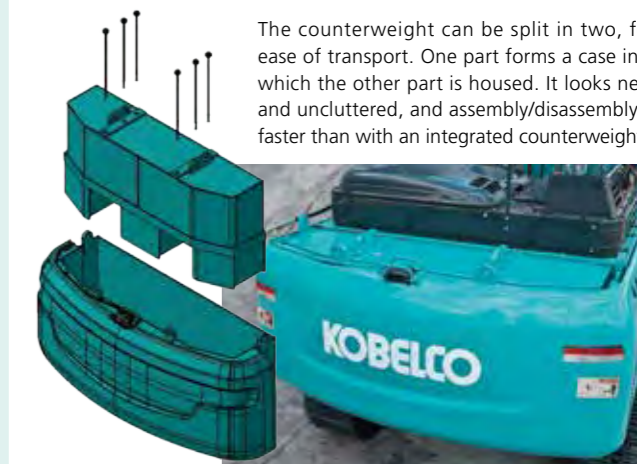

Photo shows earlier model

Boom attachments are easily changed, allowing increased machine utilisation.

Separate boom specification

KOBELCO has pioneered the development of the separate boom in Japan, and the NEXT separate boom is the product of a wealth of technologies built up through long experience in this field. By attaching a large nibbler, demolition is completed swiftly and efficiently, whether it's the lower floors of tall buildings where the concrete is thickest, or basement floors and foundations. Working ranges at ground level are extensive, and the maximum working depth is top level in all classes.

Maximum work depth

SK400D_{LC} **6,210mm**

SK350D_{LC} **6,320mm**

Note: The measurement is for the arm bucket pin position.



NEXT ultra long attachment specification

Long reach attachment specifications are for high elevation demolition carried out from ground level. Maximum working height for SK400D_{LC} is top level in their class. The machine is capable of general demolition of 8 to 9 story buildings; working height can be reduced by removing the insert boom.

Maximum work height

SK400D_{LC} 8.7m arm **Approx. 24.7m**

6.1m arm **Approx. 21.1m**

SK350D_{LC} 6.1m arm **Approx. 21.0m**

Note: The measurement is for the arm bucket pin position.



SK400D_{LC}
Ultra long attachment specification
6.1m arm + 3.5m boom insert

Fuel costs are reduced with outstanding low fuel consumption and mode selection.

Engine



A new electronically controlled engine with high power and low fuel consumption is standard. Particulate matter and NOx emissions are suppressed through the engine's high combustion efficiency, exhaust gas after-treatment equipment, and urea SCR system.



AIS (Auto Idle Stop)

This idling stop function eliminates wasteful fuel consumption while waiting between operations. The engine stops automatically when the operation lever continues to remain in the locked state. This feature can be disabled when required.

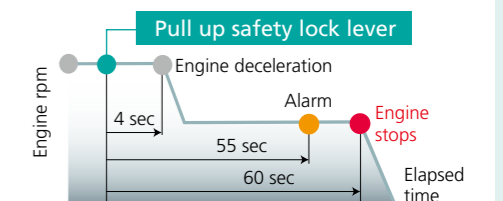

Fuel consumption mode

A function is provided for switching modes to prioritise fuel consumption depending on the work load. Modes can be switched while using any front attachment including the nibbler, breaker, or bucket.

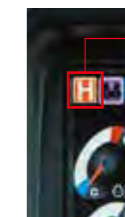

- H H mode**
When prioritising work volume
- S S mode**
When prioritising the balance between work volume and fuel consumption
- E ECO mode**
When extensively prioritising fuel consumption

Bucket / nibbler / breaker mode switch

Cluster gauge

A colour multi-display with multi-function indicators is installed. In addition to gauges and information such as fuel consumption, maintenance, working radius/boom angle, rear view camera images, the selected attachment mode and mounted front attachment are also displayed.

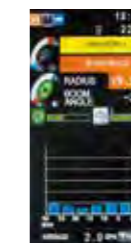

Fuel consumption

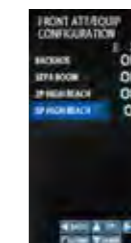

Attachment mode selection screen



Front attachment selection screen



Enhanced safety functions to assist the operator in production and performance.

New cab interference prevention system

The cab interference prevention system is standard on the SK350DLC and SK400DLC. This feature sounds an alarm and prevents the machine from allowing the working tool to come into contact with the cab during operation. Current tool position can be detected with high accuracy so the tool can be moved at close range near the cab, resulting in increased safe working range.

System configuration

The system calculates the various boom, attachment and idler link angles to create a proximity to the cab in order to prevent cab interference.



System operation

As the working tool approaches the cab, alarm is sounded before any contact can occur, and the machine automatically prevents tool from making contact with the cab.



Tilt cab

Cab support to allow tilting up to 30° is supplied as standard. The operator can maintain a comfortable posture during high elevation demolition work, suffering less fatigue over long working periods.

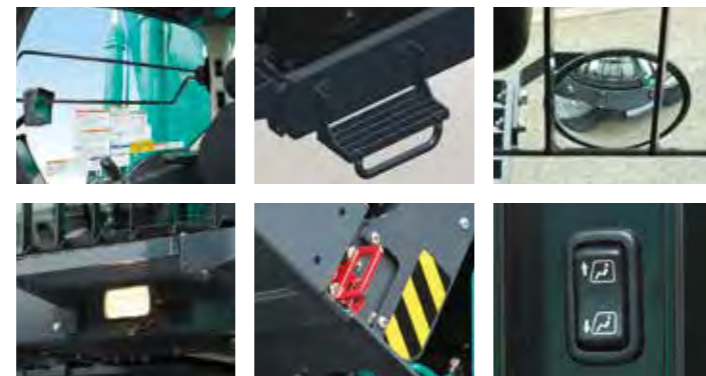

- Crosspiece on right side cab window for operator safety should the glass be broken.
- Steps installed in a position that makes it easy to get on and off. [SK400DLC]
- Cab foot mirror and cab foot light to ensure full visibility for work at machine foot.
- Maintenance stopper for greater safety during tilt mechanism maintenance.
- Alarm to prevent accidents when cab tilting is operated.
- Cab lowering device for emergencies.

Demolition special cab

The adjoining edge of the top and front windows are free of view-obstructing pillars, and radial type grid guards are installed on front and upper sides. This gives the operator an unobstructed and continuous view from ground level to the maximum working height.



- ISO 10262 level II FOPS front and top guards.
- The cab guards can be opened and closed without tools, and the glass can be cleaned easily.
- Vertical open/close roller shades that can be stopped at any position.
- Laminated front window.
- High strength security glass that complies with European PSA anti-crime standard.

Stability warning system

Machine working radius and stability are calculated from the position of the attachment, and the operator is warned with an alarm (continuous sound) where the machine's stability could be compromised.

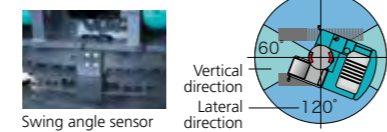

The tip over risk area will vary according to the upper orientation since the safety allowance will vary depending on the swing angle. The maximum working radius is larger when facing the vertical direction.

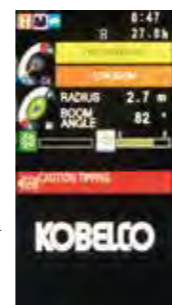

SK400DLC
Separate boom specification

Multiple standard features and accessories for ensuring safety



Rear view camera

The rear view camera is displayed on the multi-display.



Right side camera + monitor

Rear and side camera views can be displayed on the separate monitor.

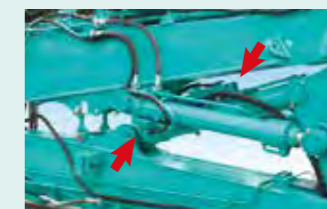

Boom, arm and jib holding valves

Standard - to prevent boom or arm from falling if a hose is damaged.



Cab with two lights

Cab mounted lights are standard.



One way call

Operator is able to alert ground workers without taking their hands off of the machine controls.



Travel alarm

The alarm cautions workers in the area that the machine is traveling.



Specialised attachment stands Option

For greater safety and efficiency during assembly, disassembly and transport.



Falling object deflector

The guard deflects falling debris away from the machine. This is standard for the ultra long attachment.

* The accessory settings may differ according to the class or specification. Refer to the list of key accessories on the back page for details.

Transportation Tie-Down Points

[SK400DLC]

On the drive motor side, the brackets are attached to the top of the lower car body as lashing points to prevent interference between the piping cover and the binding wire.

Idler side



Drive Motor side



Engineered with legendary reliability and durability for the most demanding job sites.

Factory engineered Heavy Duty boom and arm [Ultra long attachment]



- Lifting eyes are provided.
- Hoses are routed for easy maintenance.

Hydraulic oil filter restriction indicator

Clogging is detected by the pressure difference at the filter entrance and exit, and warnings are displayed on the colour multi-display. Hydraulic equipment trouble can be prevented by taking action before contaminants enter the hydraulic oil tank.

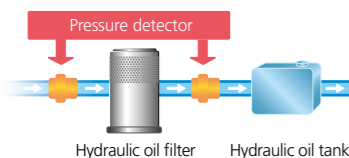

LED lights

Bright, long-life LED lights fitted to left and right of arm for ultra long attachment specification, and to left and right of boom for separate boom specification.



Dedicated arm for the ultra long attachment

Various reinforcements and protective structures are incorporated in the arm section to prevent damage from contact or flying debris.



- Guided reinforced bucket cylinder guard with box-type structure



- Electric wiring with optimised routing and full cover for preventing damage



- Hoses routed to protect from damages



- Guarded work LED lights

New crawler frame

Lower steps are mounted at the front and rear of the crawler frame, allowing easy ingress and egress to the tilting cabin, regardless of machine orientation to the undercarriage.

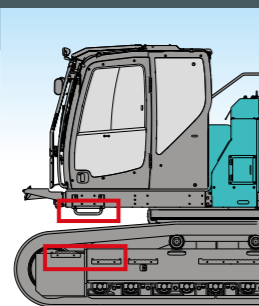

SK350DLC

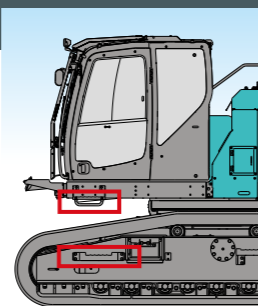

SK400DLC



SK400DLC
Ultra long attachment specification
6.1m arm + 3.5m boom insert

Demolition ready. Standard factory options, built ready to work.



Upper frame under cover guards
The 6mm thick reinforced cover protects the engine and components.

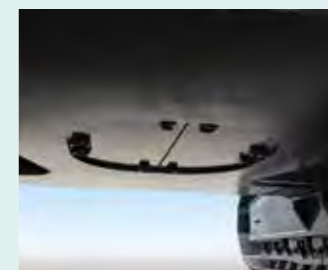

Swivel guard
The lower car body structure is fitted underneath with a 9mm thick reinforced cover.



Water spray (with drainage circuit)
A drainage circuit is newly installed to prevent rusting valves. The pipe can be drained after sprinkle water.



New hydraulic oil filter
Glass filtration material with outstanding cleaning ability and durability is used.

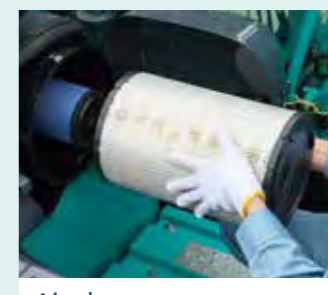

Air cleaner (double element)
The double filter structure and large capacity prevents dust from being sucked in.

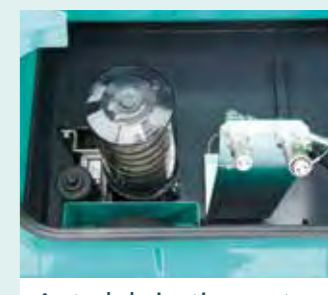

Auto lubrication system
The attachment is automatically oiled at specified times. Eliminates the trouble of oiling before starting work.



Additional tool box Option SK350DLC
A large storage box for storing tools is provided.



Reinforced guard for travel motor
Thick steel plate used to ensure strength and minimise gap with frame.



Fuel supply pump Option
Quickly and easily fuel the machine from ground level.



Battery shut-off device
Battery cut-off switch prevents battery discharge over long periods.

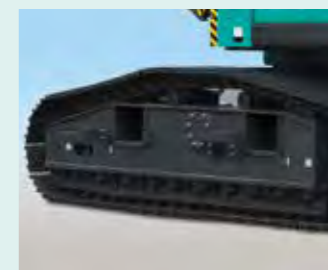

Full track guides
Reliability is increased and track retention is improved, even on rough ground and demolition debris.



Crawler extension/retraction mechanism guard [SK400DLC]
Hydraulic cylinders protected from flying demolition debris.

* The accessory settings may differ according to the class or specification. Refer to the list of key accessories on the back page for details.



Engine

	SK350DLC	SK400DLC
Model	HINO J08EYD-KSDA	
Type	Four-stroke liquid-cooled direct injection type diesel engine with intercooler turbo-charger	
No. of cylinders	6	
Bore and stroke	112 mm x 130 mm	
Displacement	7,684 L	
Rated power output	201 kW/2,100 min ⁻¹ (ISO 9249 : With fan)	213 kW/2,100 min ⁻¹ (ISO 14396 : Without fan)
Max. torque	988 N-m/1,600 min ⁻¹ (ISO 9249 : With fan)	1,017 N-m/1,600 min ⁻¹ (ISO 14396 : Without fan)



Hydraulic System

	SK350DLC	SK400DLC
Pump	Two variable displacement piston pumps + one gear pump	
Type	Two variable displacement piston pumps + one gear pump	
Max. discharge flow	2 x 294 L/min, 1 x 21.0 L/min	
Relief valve setting		
Excavating circuits (main)	31.4 MPa	
Power boost*	34.3 MPa	
Travel circuit	34.3 MPa	
Swing circuit	29.0 MPa	
Pilot control circuit	5.0 MPa	
Nibbler(Crusher) circuit	Open and Close 24.5 MPa (Factory setting)	Rotation 20.6 MPa
Main control valve	8-spool	

*Only Separate boom specification



Swing System

	SK350DLC	SK400DLC
Swing motor	One fixed displacement piston pump	
Brake	Hydraulic	
Parking brake	Wet multiple plate	
Swing speed	Separate attachment : 10.0min ⁻¹ 3-piece ultra long attachment : 5.5min ⁻¹	
Swing torque	119.6 kN·m	
Tail swing radius	3,600 mm	



Travel System

	SK350DLC	SK400DLC
Travel motors	Variable displacement piston pump with counterbalance valve	
Travel brakes	Hydraulic	
Parking brakes	Wet multiple plate	
Travel shoes	48 each side	
Travel speed (high/low)	5.6/3.3 km/h	5.6/3.3 km/h
Drawbar pulling force	310 kN (SAE)	318 kN (SAE)
Gradeability	70 % (35 deg)	



Cab & Control

	SK350DLC	SK400DLC
Cab	All-weather, sound-suppressed steel cab mounted on the high suspension mounts	
Control	Two hand levers and two foot pedals for travel	
	Two hand levers for excavating and swing	
	Electric rotary-type engine throttle	
	Tilting Cab (30°)	



Boom, Arm & Bucket

	SK350DLC	SK400DLC
3-piece ultra long attachment		
Boom cylinders	170 mm x 1,505 mm	
Arm cylinder	170 mm x 1,210 mm	
Bucket cylinder	125 mm x 1,200 mm	
Jib cylinders	140 mm x 1,210 mm	
Max. tool weight	2,600 kg (6.1m arm)	3,000 kg (6.1m arm) 2,600 kg (8.7m arm)
Separate attachment		
Boom cylinders	170 mm x 1,505 mm	
Arm cylinder	170 mm x 1,788 mm	
Bucket cylinder	150 mm x 1,193 mm	
Jib cylinders	240 mm x 1,317 mm	
Max. tool weight	4,000 kg	



Refilling Capacities & Lubrications

	SK350DLC	SK400DLC
Fuel tank	503 L	
Cooling system	35.0 L	
Engine oil	28.5 L	
Travel reduction gear	2 x 7.5 L	
Swing reduction gear	7.4 L	
Hydraulic oil tank	245 L tank oil level 410 L hydraulic system	
DEF/AdBlue® tank	83.0 L	

Operating Weight & Ground Pressure

Attachment Type	SK350DLC		SK400DLC		Separate attachment *
	3-piece ultra long attachment/ equipment *	Separate attachment *	3-piece ultra long attachment/ equipment *		
	6.1m arm		6.1m arm	8.7m arm	
Operating Weight	44,900 kg	45,300 kg	49,500 kg	49,900 kg	49,600 kg
Ground Pressure	84 kPa	85 kPa	93 kPa	93 kPa	93 kPa

* Measured with max tool weight

Dimensions

SK350D LC

Dimensions (main body + base boom)

Unit: mm

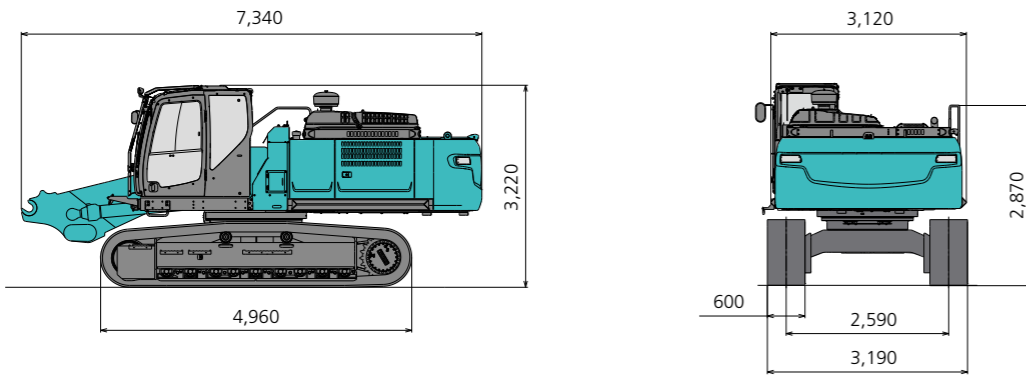

Assembled machine dimensions

Unit: mm

- Ultra long attachment : 6.1m arm + 3.5m boom insert

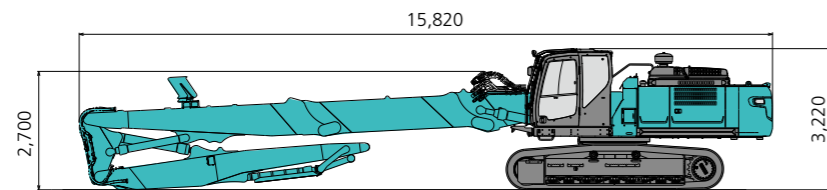

- Ultra long attachment : 6.1m arm without boom insert

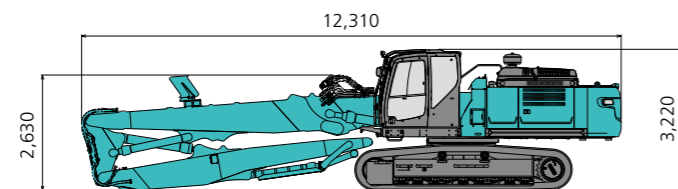

- Separate boom specification

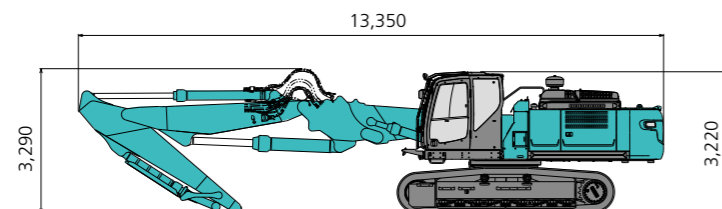

SK400D LC

Dimensions (main body + base boom)

Unit: mm

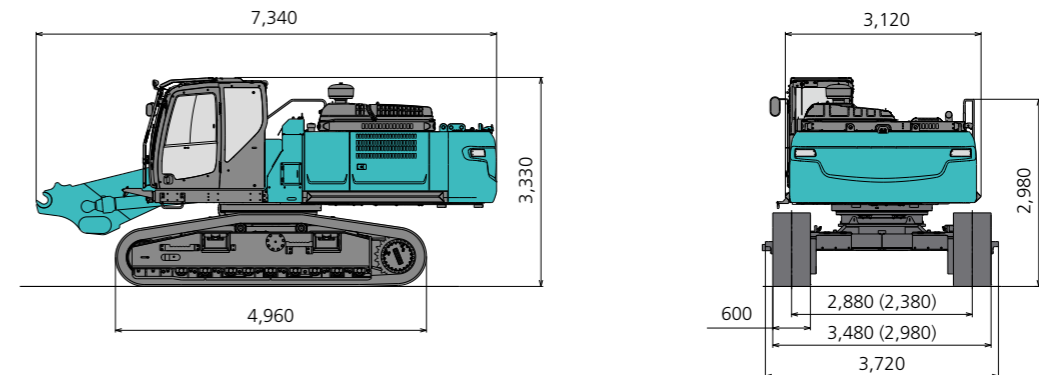

Assembled machine dimensions

Unit: mm

- Ultra long attachment : 8.7m arm + 2.4m boom insert

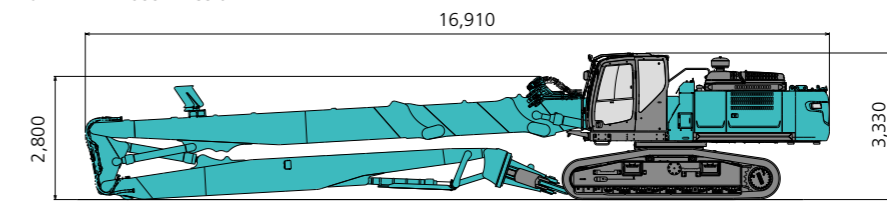

- Ultra long attachment : 8.7m arm without boom insert

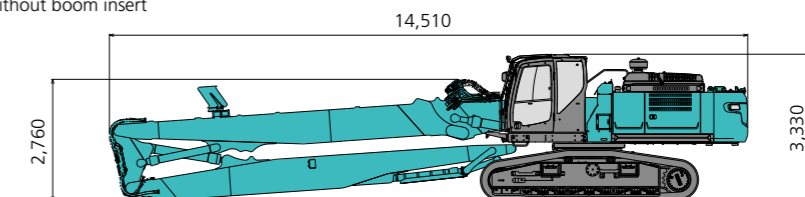

- Ultra long attachment : 6.1m arm + 3.5m boom insert

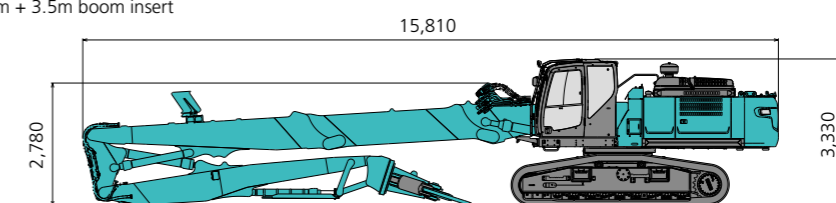

- Ultra long attachment : 6.1m arm without boom insert

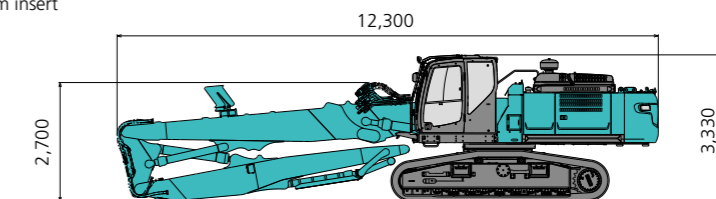

- Separate boom specification

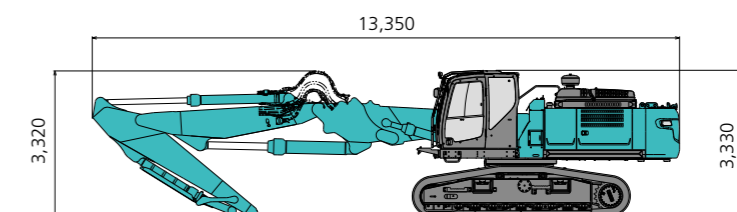

Working Ranges

SK350D LC

Unit: mm

● Ultra long attachment specification : 6.1m arm (With 3.5m boom insert)

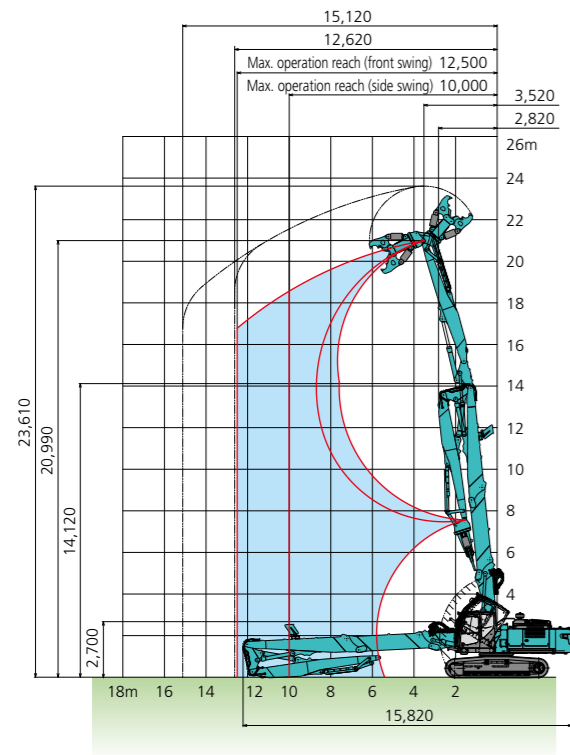

SK400D LC

Unit: mm

● Ultra long attachment specification : 8.7m arm (With 2.4m boom insert)

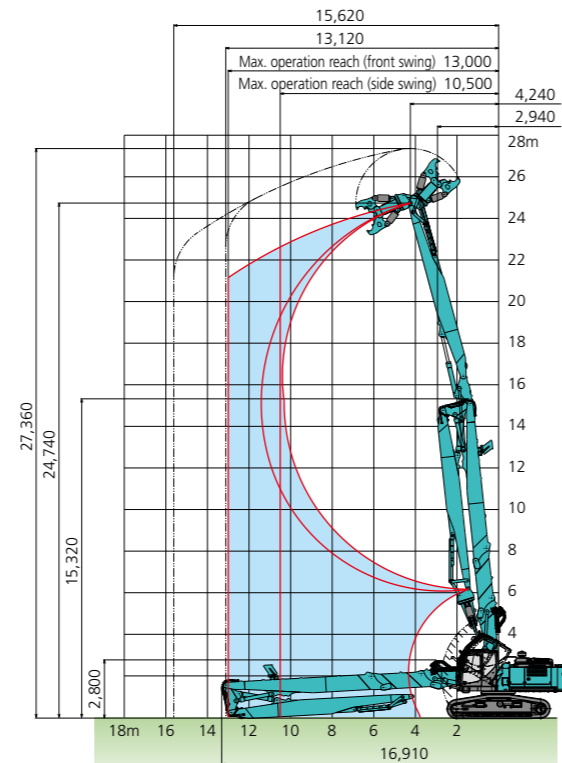

● Ultra long attachment specification : 8.7m arm (Without boom insert)

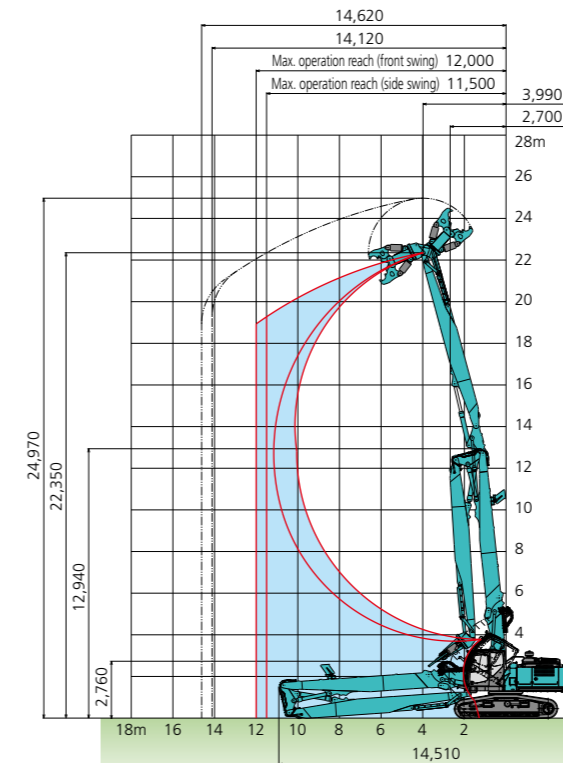

● Ultra long attachment specification : 6.1m arm (With 3.5m boom insert)

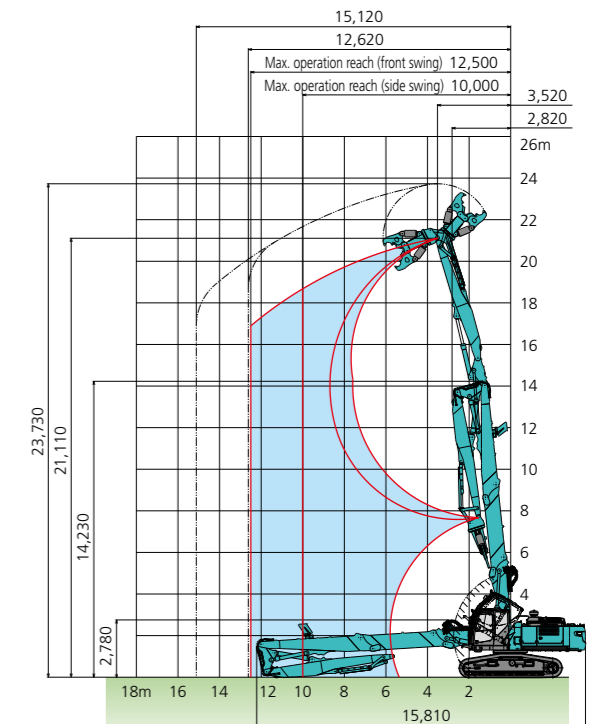

● Ultra long attachment specification : 6.1m arm (Without boom insert)

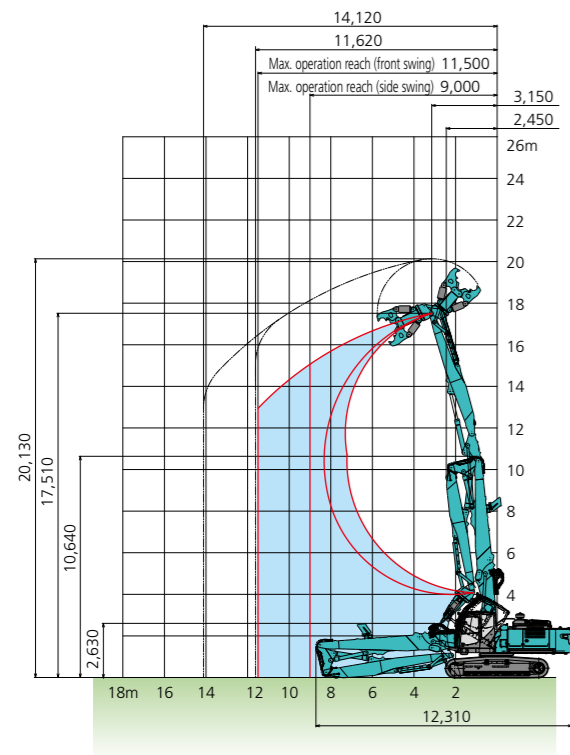

● Separate boom specification

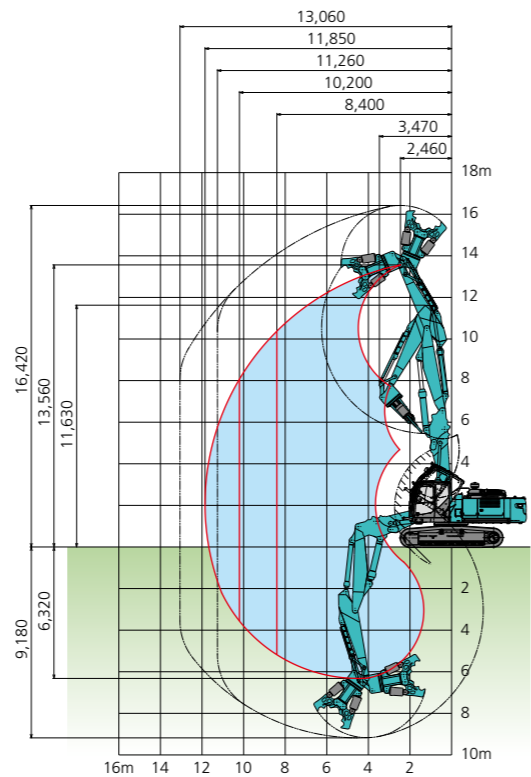

● Separate boom specification

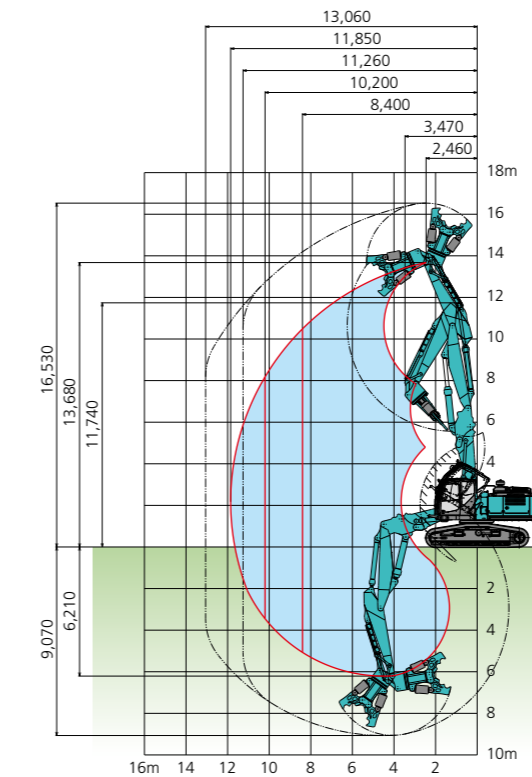

● Ultra long attachment specification : 6.1m arm (Without boom insert)

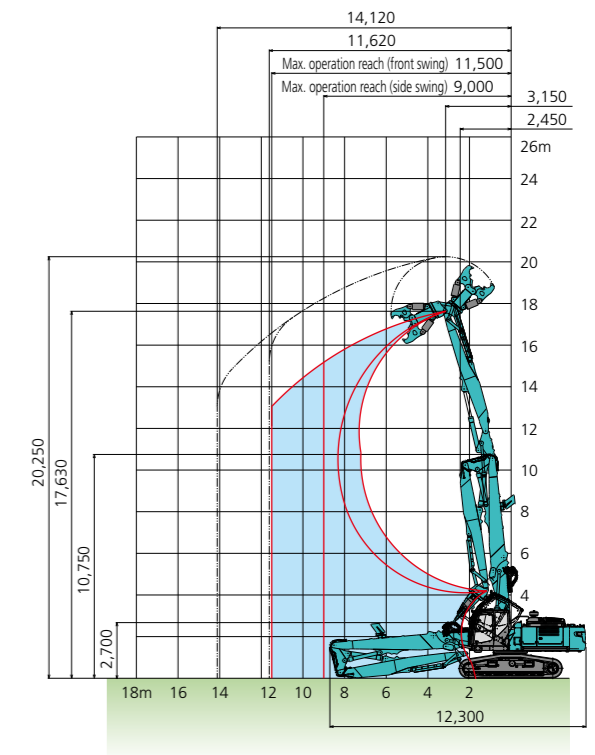

Disassembled dimensions and weight

SK350D LC

Unit: mm

<p>Main body + base boom</p> <p>Weight: 34,600 kg</p>	<p>Main body + base boom (without counterweight)</p> <p>Weight: 25,200 kg</p>
<p>Main body + base boom + boom insert</p> <p>Weight: 36,300 kg</p>	<p>Main body + base boom + boom insert (without counterweight)</p> <p>Weight: 26,900 kg</p>
<p>Counterweight</p> <p>Weight: 9,490 kg</p>	<p>Ultra long attachment : 6.1m arm + 3.5m boom insert (including enclosed stand)</p> <p>Overall width: 1,770 mm Weight: 7,690 kg</p>
<p>Ultra long attachment : 6.1m arm (including enclosed stand)</p> <p>Overall width: 1,770 mm Weight: 5,990 kg</p>	<p>Ultra long attachment : 3.5m boom insert (including optional stand)</p> <p>Overall width: 920 mm Weight: 1,940 kg</p>
<p>Separate boom (including enclosed stand)</p> <p>Overall width: 1,770 mm Weight: 6,720 kg</p>	

SK400D LC

Unit: mm

<p>Main body + base boom</p> <p>Weight: 38,900 kg</p>	<p>Main body + base boom (without counterweight)</p> <p>Weight: 28,800 kg</p>
<p>Main body + base boom + 3.5m boom insert</p> <p>Weight: 40,600 kg</p>	<p>Main body + base boom + 3.5m boom insert (without counterweight)</p> <p>Weight: 30,500 kg</p>
<p>Main body + base boom + 2.4m boom insert</p> <p>Weight: 40,300 kg</p>	<p>Main body + base boom + 2.4m boom insert (without counterweight)</p> <p>Weight: 30,200 kg</p>
<p>Counterweight Case</p> <p>Weight: 3,260 kg</p>	<p>Counterweight</p> <p>Weight: 6,860 kg</p>
<p>Ultra long attachment : 8.7m arm + 2.4m boom insert (including enclosed stand)</p> <p>Overall width: 1,770 mm Weight: 8,520 kg</p>	<p>Ultra long attachment : 8.7m arm (including enclosed stand)</p> <p>Overall width: 1,770 mm Weight: 7,100 kg</p>
<p>Ultra long attachment : 2.4m boom insert (including optional stand)</p> <p>Overall width: 920 mm Weight: 1,670 kg</p>	<p>Ultra long attachment : 6.1m arm + 3.5m boom insert (including enclosed stand)</p> <p>Overall width: 1,770 mm Weight: 7,690 kg</p>
<p>Ultra long attachment : 6.1m arm (including enclosed stand)</p> <p>Overall width: 1,770 mm Weight: 5,990 kg</p>	<p>Ultra long attachment : 3.5m boom insert (including optional stand)</p> <p>Overall width: 920 mm Weight: 1,940 kg</p>
<p>Separate boom (including enclosed stand)</p> <p>Overall width: 1,770 mm Weight: 6,720 kg</p>	

STANDARD EQUIPMENT

Note: Standard and optional equipment may vary. Consult your KOBELCO dealer for specifics.

ENGINE

- Turbocharged and inter-cooled HINO J08EYD-KSDA Diesel engine
- Automatic engine deceleration
- Auto Idle Stop (AIS)
- Batteries (2 x 12V - 96Ah)
- Starting motor (24V - 5 kW), 60 amp alternator
- Removable radiator clean-out screen
- Automatic engine shut-down if low engine oil pressure
- Side by side oil, hydraulic and engine radiators
- Double-element air cleaner

CONTROL

- Working mode selector (H-mode, S-mode and ECO-mode)
- Power Boost (only separate boom specification)

HYDRAULIC

- Auto warm-up system
- Hydraulic oil cooler
- Hydraulic oil filter condition indicator
- Hydraulic oil for cold climates
- Quick hitch piping
- Multi-coupler (QH line x 2, rotation line x 2, jib & arm pilot line x 2, drain x 1)
- Hydraulic oil clog sensing

SWING SYSTEM & TRAVEL SYSTEM

- Swing rebound prevention system
- Two-speed travel with automatic down shift
- Sealed & lubricated track links
- 600mm grouser shoes
- Grease-type track adjusters
- Automatic swing brake
- Hydraulic retractable crawler (SK400DLC)

MIRRORS, LIGHTS & CAMERAS

- Two rearview mirrors
- Rear-view camera
- Three front working lights (1 on upper carriage, 2 on cab)
- Attachment front work light (separate boom: 2, ultra long attachment: 2)
- Right side camera, additional monitor
- Cab foot light
- Cab foot mirror

CAB & CONTROL

- Tilt cab
- Demolition special cab
- Electric horn
- All-weather, sound-insulated cab
- P5A glass
- Easy to read multi-display monitor
- Automatic climate control
- Defroster
- Air suspension seat with heater
- Headrest
- Bluetooth® installed radio (AM/FM Stereo with speakers)
- Luggage tray
- Large cup holder
- Detachable two-piece floor mat
- Handrails
- Wiper (top and front window)
- Emergency escape hammer
- Common use attachment pressure drain
- Manual DPF regeneration switch
- 12 V converter
- Tip-over warning device
- Cab interference prevention system

- Boom & arm & jib cylinder holding valves
- Slow return check valves
- 9mm thick swivel guard
- 6mm thick upper frame under cover guards
- Auto greasing system
- Rotation and N&B auxiliary circuits and piping
- Stand for Ultra long and Separate Attachment
- Falling object deflector
- One way call
- Remote machine monitoring system "GEOSCAN"
- Additional tool box (SK400DLC)

- Cab tilt operation alarm
- Cab emergency lowering device
- Crosspiece for operator safety in cab
- Console tilt
- Cab tilt maintenance stopper
- Battery shut-off
- Travel alarm
- Full track guides

OPTIONAL EQUIPMENT

- Fuel supply pump
- Stand for 3.5m (2.4m) insert and 3.5m adapter
- Extended hand rail
- Pin removal equipment
- Water spray for separate boom and ultra long attachment
- Lower tool box (SK350DLC)
- 800mm, 700mm grouser shoes (SK350DLC)

Note: Bluetooth® is a registered trademark of the Bluetooth SIG Inc. AdBlue® is a registered trademark of the Verband der Automobilindustrie e.V. (VDA).

Note: This catalog may contain attachments and optional equipment that are not available in your area. And it may contain photographs of machines with specifications that differ from those of machines sold in your areas. Please consult your nearest KOBELCO distributor for those items you require.

Specialist equipment is needed to use this machine in demolition work. Before using it please contact your KOBELCO dealer.

Due to our policy of continuous product improvements all designs and specifications are subject to change without advance notice.

Copyright by **KOBELCO CONSTRUCTION MACHINERY CO., LTD.** No part of this catalog may be reproduced in any manner without notice.

KOBELCO CONSTRUCTION MACHINERY CO., LTD.

5-15, Kitashinagawa 5-chome, Shinagawa-ku, Tokyo 141-8626 JAPAN
Tel: +81 (0) 3-5789-2146 Fax: +81 (0) 3-5789-2135
<https://www.kobelcocm-global.com/>

Inquiries To: